

### FRLS 50 W

Technical data FRLS 50 W			
Motor data	Symbol	Unit	FRLS052 __A4 __
Nominal voltage	V	VAC	220
Nominal power	W	W	50
Nominal torque	$T_C$	Nm	0.16
Nominal current	$I_C$	$A_{eff}$	0.9
Peak torque for 1 sec.	$T_P$	Nm	0.48
Peak current for 1 sec.	$I_P$	$A_{eff}$	2.7
Nominal speed	$n_N$	rpm	3,000
Maximum speed for 1 sec.	$n_{max}$	rpm	4,500
Torque constant	$K_T$	Nm/ $A_{eff}$	0.178
Voltage constant	$K_e$	$V_{eff}/(1,000 \text{ rpm})$	10.74
Winding resistance <sup>1)</sup>	R	$\Omega$	4.7
Winding inductance <sup>1)</sup>	L	mH	4.7
Mass inertia of rotor	J	$kgm^2 \times 10^{-4}$	0.02
Mass inertia of rotor with brake	J	$kgm^2 \times 10^{-4}$	0.022
Motor weight	M	kg	0.45
Motor weight with brake	M	kg	0.58
Motor insulation class			A
<b>Motor brake (optional)<sup>2)</sup></b>			
Braking torque (static)	$T_b$	Nm	0.3
Power supply	V	VDC	$24 \pm 10\%$
Power consumption	A	A	0.3
Rated input	W	W	6.0
Response time open	$t_0$	ms	30.0
Response time close	$t_R$	ms	20.0

<sup>1)</sup> Line to line

<sup>2)</sup> The motor brakes are holding brakes only, not operating brakes



Torque-speed curve FRLS 50 W

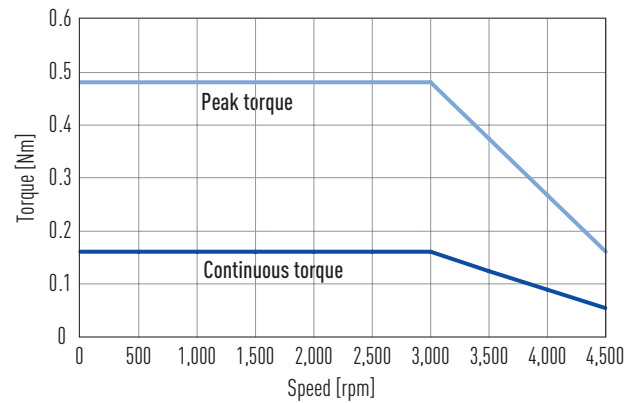

### Dimensions FRLS 50 W:

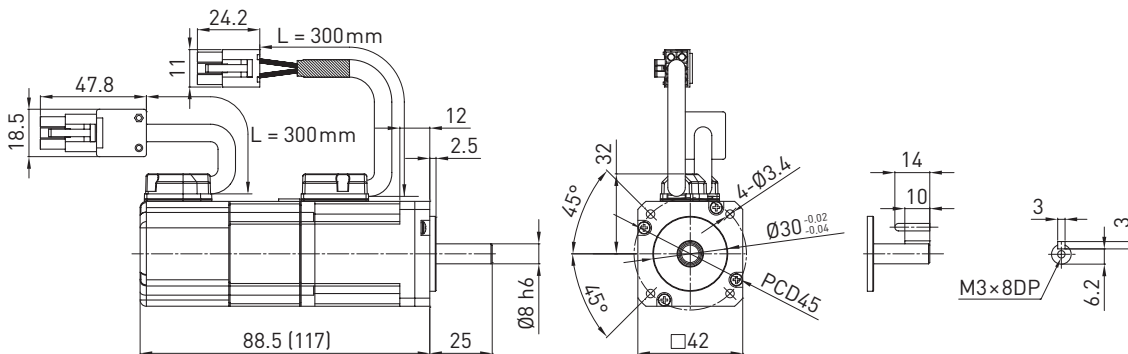

Values in brackets apply to model with motor brake